

# PICAXE CONNECT (AXE210)

## Description:

The AXE210 Connect board has been designed as an experimental project board for users wishing to learn how to interface a PICAXE chip to the Maxstream XBee module or a LocSense GPS module.

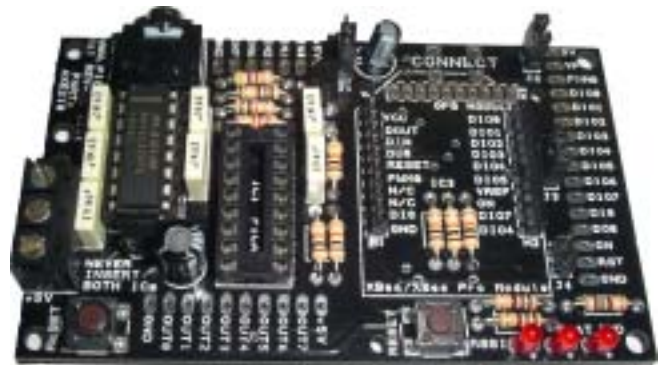

## Use with XBee Wireless Modem

When considering a wireless PICAXE application most users will compare the 2.4GHz XBee modem units with the slightly lower-cost 433MHz RF modules.

Whilst the 433 modules are low cost and may be suitable for some very simple PICAXE applications, the XBee modules offer considerable advantages. The primary advantage is that the XBee modules are 'bi-directional'. Most budget 433 systems only transmit in one direction, so the transmitter has no idea whether the receiver is actually getting the data! The XBee modules transmit and receive in both directions, so you can easily test (at both ends) if the system is working correctly.

The second advantage is that of unique addressing. Each XBee unit has a unique serial number. This means two (or more) units can be set up to exclusively talk to each other, ignoring all signals from other modules. This is not easily achieved with 433 modules.

The third advantage is that the XBee module has in built 'data-packet' building and error-checking to ensure reliable data transmission.

Finally the XBee protocol allows for a number of 'channels'. By setting different units on different channels additional interference can be avoided.

Typical wireless networks could include

- |                                |  |
|--------------------------------|--|
| PC to remote PICAXE            | e.g. remote control of robot/equipment             |
| remote PICAXE to PC            | e.g. data collection from a greenhouse             |
| multiple remote PICAXEs to PC  | e.g. a security system                             |
| remote PICAXE to remote PICAXE | e.g. different sensor modules of a weather station |



The Maxstream XBee module is available from  
[www.techsupplies.co.uk](http://www.techsupplies.co.uk) XBE001

## Use with a GPS module

The AXE210 Connect board can also be used to interface to the LocSense LS-40EB-3V or LS-41EB-3V GPS module, to provide a PICAXE to GPS project/experimentation board. It is not possible to use both XBee and GPS modules at the same time.

The LocSense LS-40EB-3V (or LS-41EB-3V) GPS module is available from  
[www.techsupplies.co.uk](http://www.techsupplies.co.uk) GPS001  
Farnell 856-8316

An external active antenna for the module is also available (apply 3.3V to Ext Ant pin)  
[www.techsupplies.co.uk](http://www.techsupplies.co.uk) GPS002  
Farnell 856-8359



It is recommended that 3 nylon support posts are also purchased, part GPS003.

### Principles of Operation

The PICAXE 'AXE210 Connect Board' has been designed to support:

two XBee modes of use:

- as a computer to XBee wireless modem interface (MAX3232 chip inserted)
- as a PICAXE to XBee wireless modem interface (PICAXE chip inserted)

or two GPS modes of use:

- as a computer to GPS interface (MAX3232 chip inserted)
- as a PICAXE to GPS interface (PICAXE chip inserted)

#### Important Note:

When used as a PICAXE interface a PICAXE chip is inserted in the 18 pin socket.

When used as a computer interface a MAX3232CPE chip is inserted in the 16 pin socket.

**Never insert both the PICAXE chip and MAX3232 chip at the same time!**

### Circuit Diagrams (MAX3232 chip inserted)

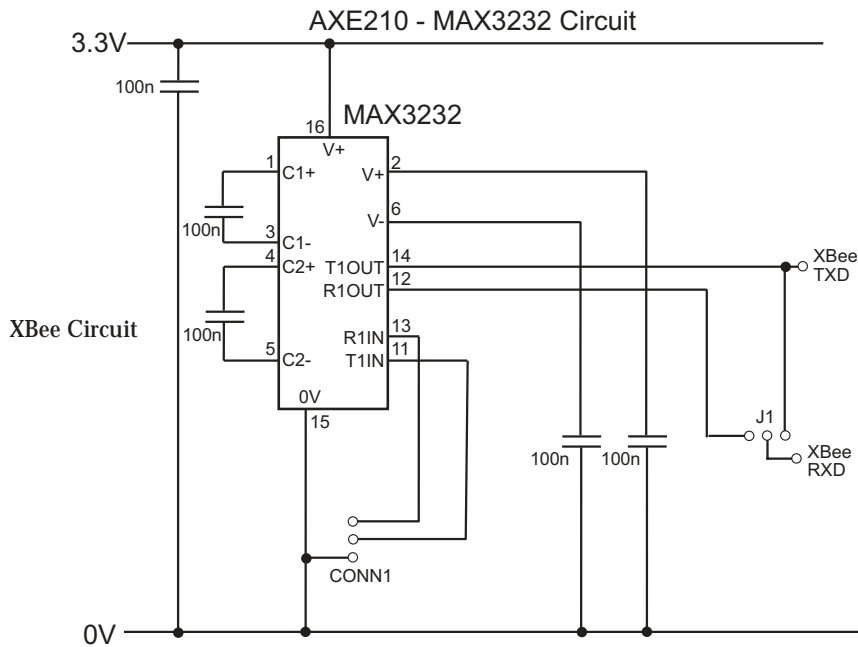

Please note that Sipex SP3232EUCP and Maxim MAX3232CPE are equivalent parts (from different manufacturers) and either may be supplied in the kit (depending on current availability).

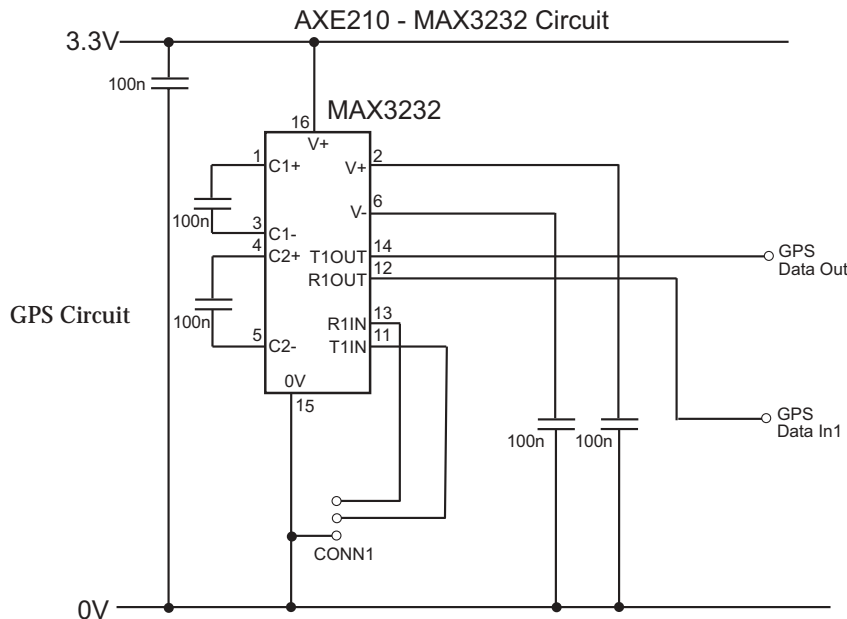



### Serial/USB Cable Connection

The Connect board has a 'stereo' type socket for connection of the PICAXE serial cable, part AXE026. This cable is used for PICAXE downloads when a PICAXE chip is connected, or direct computer communication with the XBee/GPS module when the MAX323 chip is fitted.

If you only have access to a USB port you will also require the PICAXE USB cable, part AXE027.

### Power Supply

**IMPORTANT - SEE ADDENDUM OVERLEAF.**

For experimentation work the AXE210 is designed to work from a regulated 9V or 5V DC supply. It can also be used with batteries (4.5V from 3xAA cell).

The ground (0V) connection is via the centre terminal of connector CONN2. A 9V regulated DC supply can be connected to the top terminal. Alternately a regulated 5V DC supply (or 4.5V battery pack) can be connected to the bottom terminal.

For ease of use whilst experimenting, the AXE210 contains both a 5V and 3.3V regulator. The PICAXE chip (and therefore also its output pins) operate at 5V. The XBee/GPS module operates at 3.3V. Therefore when connecting a PICAXE output pin to the module it is necessary to use a voltage divider circuit to step down the 5V PICAXE output to 3.3V (see circuit diagrams). Connecting 5V directly to the module will cause damage to the module.

The regulators are convenient for experimentation. However when powered by batteries, the 5V and 3.3V regulators are fairly inefficient and so will draw a few mA of standby current. This is not ideal for long term battery powered installations and so in this situation it is recommended that the end user considers using a permanent 3.3V supply and modifying the board to remove

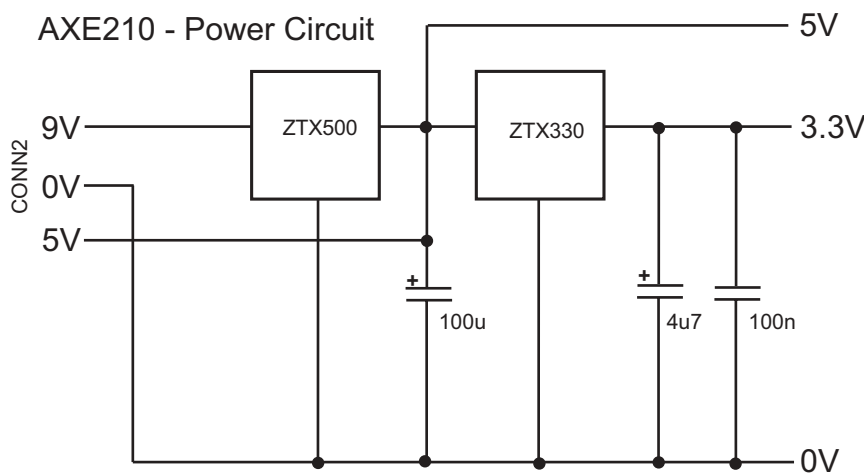

these regulators.

Connection of a higher voltage (e.g. a 9V PP3 battery) to the 5V input, or accidentally reversing the power supply connections, will damage the ICs and modules. These will then require replacing.

Note that the voltage regulators are rated to 200mA. This is suitable for the XBee or GPS modules. The MaxStream 'XBee Pro' module can draw currents greater than 200mA and so the regulator will need upgrading for use with this unit.

## AXE210 Power Supply - ADDENDUM

Since this kit was first developed the Zetex regulators the PCB was designed for have been discontinued. Unfortunately it has not been possible to source a direct equivalent. Therefore a substitution is made as follows:

RG1	ZTX500	now	MCP1702-500
RG2	ZTX330	now	MCP1702-330

The two parts DO NOT have the same pinout. Therefore it is necessary to 'twist' the 0V and Vin legs and reverse the part to fit the original PCB layout. After soldering carefully inspect to ensure the legs do not touch and cause a short circuit.

We apologise for this inconvenience which is beyond our control.

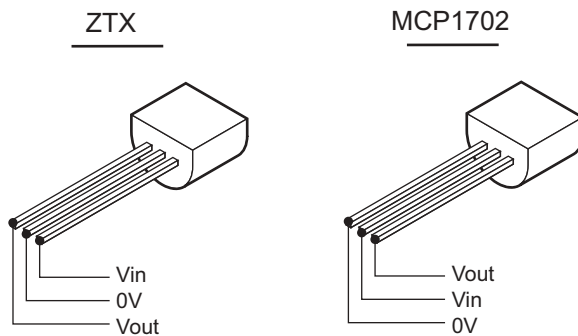

PCB is designed for ZTX part. Therefore Vin and 0V must be twisted over for MCP1702 part.

## LED indicators

The AXE210 board has three LED indicators.

### XBEE Module

RSSI connects to the XBee RSSI (pin 6)  
 STATUS connects to the XBee ON/Sleep pin (pin 13)  
 IND connects via Jumper 3 to either XBee  
     Associate (pin 15) or Transmit (pin 11)

RSSI indicates the XBee received signal strength  
 STATUS indicates whether the XBee module is active/sleeping  
 IND indicates whether the XBee module has associated with another  
 module (Associate) or is transmitting data (Transmit).

### GPS Module

RSSI connects to the GPS 1PPS pin (pin 6)  
 STATUS connects to the GPS PIO pin (pin 5)  
 IND not used

RSSI indicates the GPS status  
 STATUS indicates the UTC second (see GPS datasheet)

## Jumper Function (XBee Module only)

The AXE210 board has 4 jumpers, labelled J1 to J4.  
 These jumpers should not be fitted or used with the GPS module.

The operation of each jumper when used with the XBee module is shown below.  
 The default position of each jumper is shown in **bold** \*.

J1  
 Open - (not used)  
**Top \*** - **Normal use**  
 Bottom - Loopback test (XBee DOUT connected to DIN)

J2  
 Open - XBee Vref not connected  
**Fitted \*** - **XBee Vref connected to 3.3V**

J3  
 Open - IND. LED not connected  
 Top - IND. LED connected to XBee Transmit (DIO4)  
**Bottom \*** - **IND. LED connected to XBee Associate (DIO5)**

J4  
**Open \*** - **PICAXE output 6 not connected**  
 Fitted - PICAXE output 6 connected to XBee sleep pin (DI8)

## Assembly instructions:

The AXE210 Connect board is a high quality plated through PCB and is therefore relatively straight forward to assemble. However a number of the electronic components are polarised, so please ensure these components are fitted the correct way around before soldering (see table below). Soldering experience is assumed.

Tools required (not supplied):

- Soldering iron and solder
- Side Cutters
- Small pair of pliers

## Contents:

• PCB	1	AXE210 Connect PCB	
• IC1	1	18 pin IC socket	
• IC2	1	16 pin IC socket	
• R1	1	4k7 resistor (yellow violet red gold)	
• R2-5	4	180 resistor (brown grey brown gold)	
• R6-12	7	10k resistor (brown black orange gold)	
• R13	1	22k resistor (red red orange gold)	
• C7-8	7	100nF (104) polyester capacitor	
• C1	1	100uF electrolytic capacitor	*** + marked on PCB
• C9	1	4.7uF electrolytic capacitor	*** + marked on PCB
• LED1-3	3	3mm LED	*** flat marked on PCB
• RG1	1	ZSR500 5V regulator	*** SEE ADDENDUM PAGE 5 ***
• RG2	1	ZSR330 3V regulator	*** SEE ADDENDUM PAGE 5 ***
• S1-2	2	miniature push switch	
• CONN1	1	3.5mm stereo socket	
• CONN2	1	3 pin screw terminal block	
• J1-4	1	10 pin header (snap into 2x3 and 2x2)	
• J1-4	4	jumper links	
• H1,2	2	10 pin connector	
• BAT1	1	battery clip	
• BAT1	1	4.5V (3xAA) battery box	
• IC2	1	MAX3232CPE (or equivalent SP3232EUCP)	*** pin 1 faces up

(\*\*\* denotes components which must be soldered the correct way around. See notes above).

## Important Information for GPS Use:

The following extra information about assembly is important for GPS module users:

- Resistors R10, R11, R12 are not fitted.
- Headers J1, J2, J3, J4 are not fitted.
- Sockets H1 and H2 are not used. Instead solder one socket in the H3 position.
- The reset switch SW2 is soldered in the top position (over the word 'CONNECT') - if placed in the normal lower position it will be under the GPS module and so not accessible.
- The LEDs must be soldered at right angles to the PCB (see photo overleaf) to avoid contact with the GPS module.
- It is recommended that the GPS module is supported by three plastic support posts (available separately as part GPS003). However due to supply difficulties it has been necessary to substitute support posts that require a 2.5mm hole on the AXE210 PCB (the holes are currently drilled to 2mm). Therefore it is necessary for the user to carefully drill out the 3 support holes on the PCB to 2.5mm before using the support posts provided in kit GPS003.

**Assembly Instructions:**

1. Solder the resistors in position.  
Do not insert resistors R10-R12 if using the GPS module.
2. Solder the two IC sockets and push switch S1 in position.
3. XBee - solder switch S2 in position.  
GPS - solder switch over the word CONNECT (not in position S2)
4. Solder the capacitors and LEDs in position.  
If using the GPS module the LEDs should be inserted at right angles to the PCB.
4. \*\*\* SEE ADDENDUM PAGE 5 \*\*\* Solder the RG1 (ZSR500) and RG2 (ZSR330) regulators in position.
5. Solder the CONN1 and CONN2 connectors in place. Ensure the stereo socket 'clicks' into position flat on the PCB prior to soldering.
6. XBee - Solder the headers H1, H2 and jumpers J1-4 in position.  
GPS - Solder the header H3 in position

**Assembled board (XBee):**



**Assembled board (GPS):**



## XBee / PICAXE Connections

The PICAXE input pins are connected to solder pads at the top of the board.  
The PICAXE output pins are connected to solder pads at the bottom of the board.  
The XBee pins are connected to solder pads on the right hand side of the board.

### PICAXE to XBee Connection

When a PICAXE chip is inserted in the 18pin socket the following connections are made:

PICAXE output7 is connected to the XBee transmit pin (via jumper J1).  
PICAXE output6 is connected to the XBee sleep pin (via jumper J4)  
PICAXE input7 is connected to the XBee receive pin.

Therefore data to be transmitted by the XBee module can be output via the PICAXE command serout e.g.

```
serout 7,T2400,("Data")
```

Data received by the XBee module can be processed by the PICAXE command serin e.g.

```
serin 7,T2400, b1
```

When configured for external pin activated sleep, the XBee module can be put to sleep / woken from sleep by the PICAXE commands high and low e.g.

```
high 6 / low 6
```

Note that hardware controlled sleep needs to be configured by the XBee Wizard – the default condition is no hardware sleep control. Jumper 4 must also be fitted.

Remember - never insert both the PICAXE chip and MAX3232 chip at the same time.

### Computer to XBee Connection

When a MAX3232 chip is inserted in the 16pin socket the XBee module is connected (via the download cable) directly to the computer serial port. Therefore data can be transmitted from/received by the computer. The XBee module can also be configured via use of the XBee Wizard or configuration commands (see XBee datasheet XBE001.pdf and tutorial AXE210\_XBEE.pdf for more details).

If your laptop computer does not have a conventional 9 pin serial port you will require the PICAXE USB download cable - part AXE027.

For further information about using the XBee module with the PICAXE chip please see the separate XBee tutorial datasheet (datasheet AXE210\_XBEE.pdf available from the datasheets section at [www.picaxe.co.uk](http://www.picaxe.co.uk))

Remember -  
never insert both the PICAXE chip and MAX3232 chip  
at the same time.

## GPS / PICAXE Connections

The PICAXE input pins are connected to solder pads at the top of the board.  
 The PICAXE output pins are connected to solder pads at the bottom of the board.  
 The GPS pins are connected to solder pads on the right hand side of the board.

### Computer to GPS Connection

When a MAX3232 chip is inserted in the 16pin socket the GPS module is connected (via the download cable) directly to the computer serial port. Therefore data can be transmitted from/received by the computer. The GPS module can also be configured via use of the GPS Wizard or configuration commands (see GPS datasheet GPS001.pdf for more details).

If your laptop computer does not have a conventional 9 pin serial port you will require the USB adapter (part USB010 – cost around £5).

### PICAXE to GPS Connection

When a PICAXE chip is inserted in the 18pin socket the following connections are made:

GPS Pin	AXE210 Function	AXE210 Solder Pad
1 Data Out	PICAXE Input 7	IN7
2 Data In	PICAXE Output 7	OUT7
3 Vcc	+3.3V	3V
4 GND	Ground	GND
5 PIO	Status LED	ON
6 1PPS	RSSI LED	PWM0
7 Reset	Reset Switch	RST
8 Data In 2	(optional) Output 6*	DI8
9 VBAT	-	DIO1
10 Ant Pwr	(link to 3V for active ant.)	DIO0

\*Data In 2 to PICAXE connection is enabled by soldering a wire link in the J4 position and adding resistors R10, R11, R12 (all 10k) to the board.

For further information about using the GPS module with the PICAXE chip please see the separate GPS tutorial datasheet (datasheet AXE210\_GPS.pdf, available from the datasheets section at [www.picaxe.co.uk](http://www.picaxe.co.uk))

Please remember:

Never insert both the PICAXE chip and MAX3232 chip at the same time.

When using an 'active' antenna (eg GPS002) it is necessary to connect GPS 'Ant Pwr' to 3.3V (ie connect pads DIO0 & 3V together)

The GPS Module requires a clear view of the sky to operate (i.e. will not operate correctly in a building).

The GPS module may require 5 minutes or more after original power-up to locate the satellite signal (see GPS datasheet).